

ATTACHMENT A

SITE MAP – PROPOSED BEBAN COMMUNITY BIKE PARK

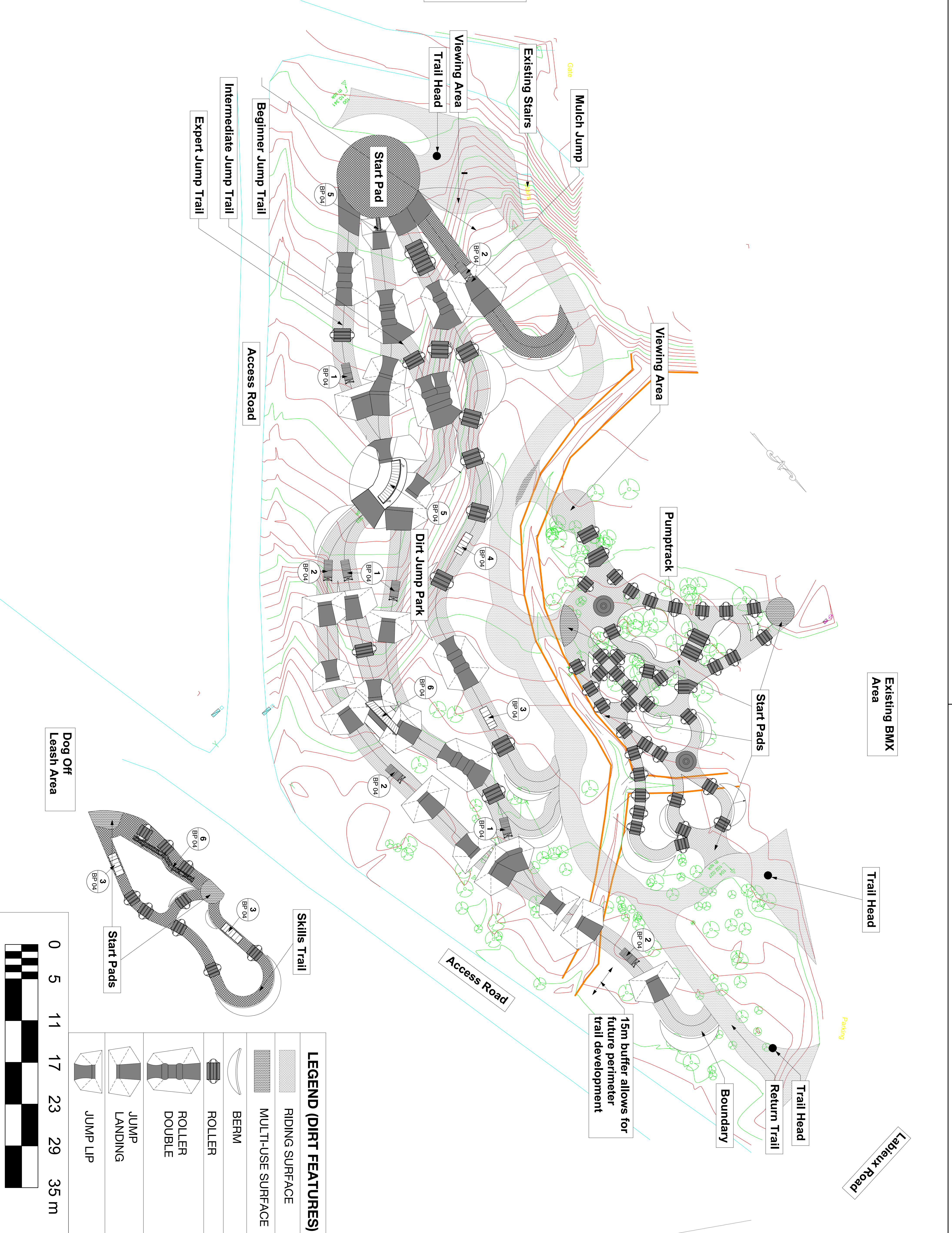

Agricultural Area



Dog Off Leash Area

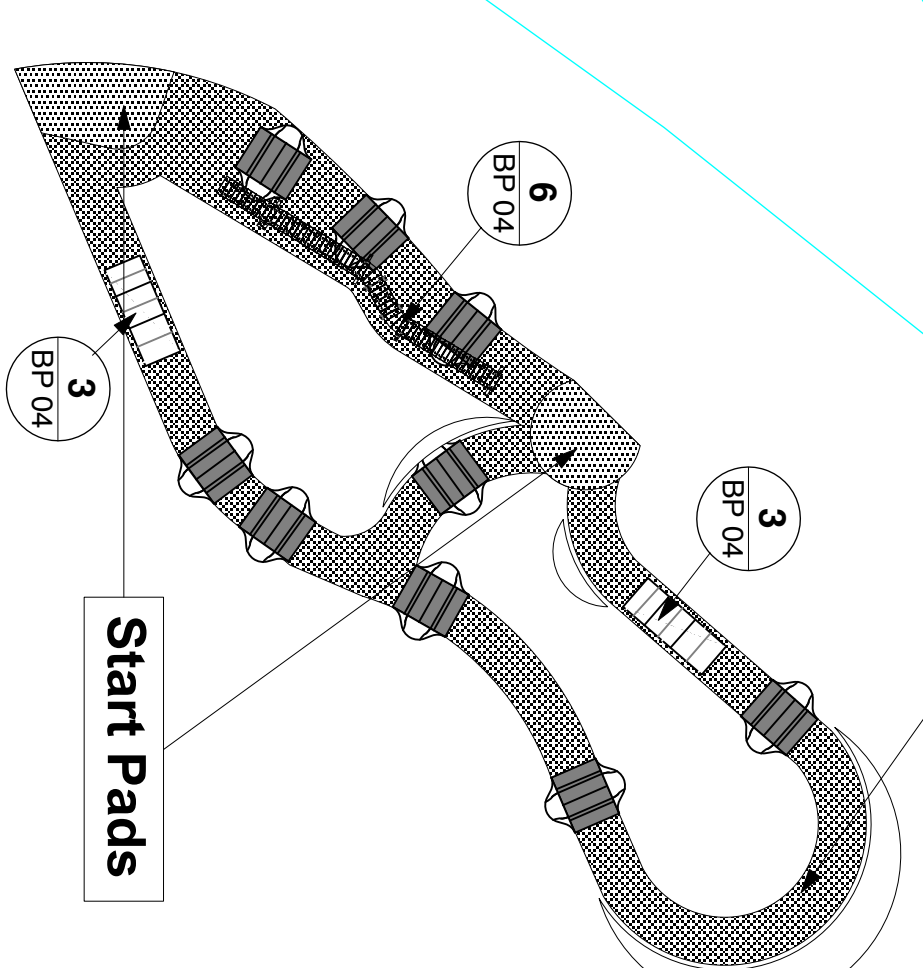

LEGEND (DIRT FEATURES)

[Symbol]	RIDING SURFACE
[Symbol]	MULTI-USE SURFACE
[Symbol]	BERM
[Symbol]	ROLLER
[Symbol]	ROLLER DOUBLE
[Symbol]	JUMP LANDING
[Symbol]	JUMP LIP

0 5 11 17 23 29 35 m

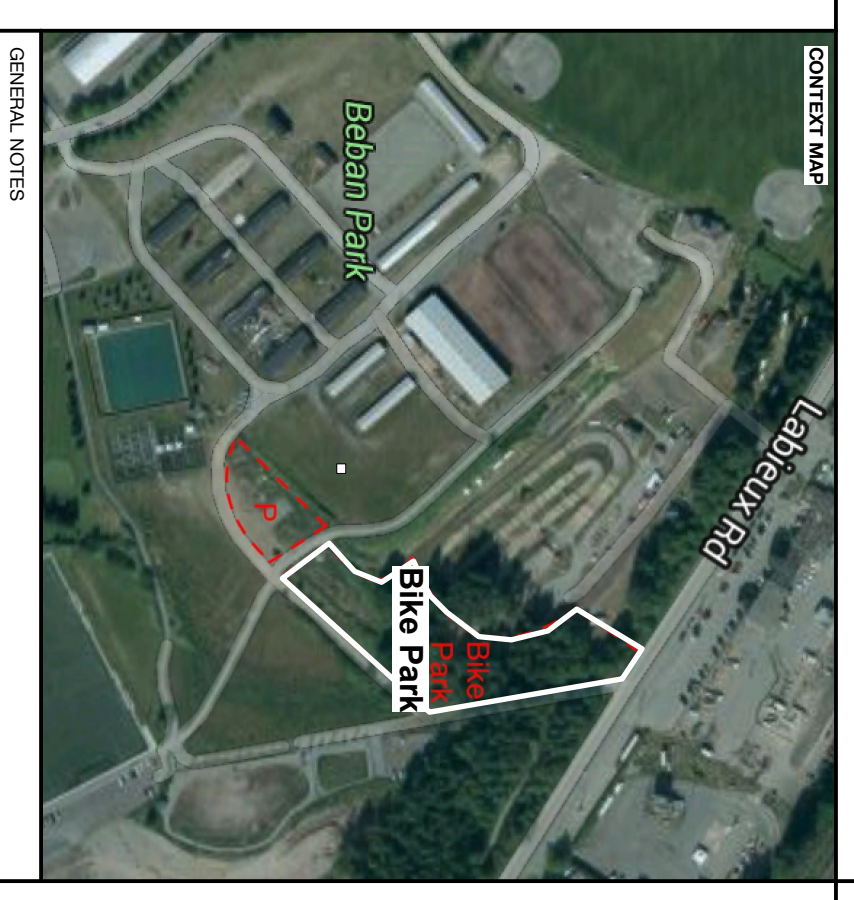
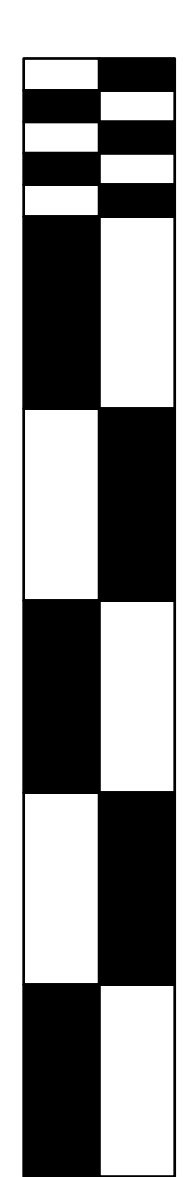

GENERAL NOTES
 Concept Design - NOT FOR CONSTRUCTION
 Final alignment of all trails identified to be determined during the detailed design phase by the successful consultant / contractor and approved owner's representative prior to construction.

PROFESSIONAL STAMP

NORTH ARROW

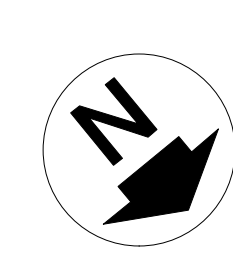

REV.	DATE	DESCRIPTION	DESIGN	DRAFTING	REVIEW
D	16-08-22	DESIGN DEVELOPMENT	CI	CI	JD
C	16-08-22	FINAL CONCEPTUAL DESIGN	CI	CI	JD
B	16-08-18	CONCEPTUAL DESIGN DEVELOPMENT	CI	CI	JD
A	16-07-12	CONCEPTUAL DESIGN (V)	CI	CI	JD
REV.	VY-AM-010	DESCRIPTION			

City of Nanaimo
 455 Wallace Street
 Nanaimo, BC V9R 5A6

ALPINE BIKE PARKS CANADA
 1000 West Beaver Creek Rd
 West Vancouver, BC V8L 1B1
 CANADA
 1-800-924-6690
 1-604-962-1951
 www.alpinebikeparks.com

PROJECT
STEVIE SMITH BIKE PARK

DRAWING TITLE
BIKE PARK FEATURE PLACEMENT

SHEET NUMBER	SCALE	CONSULTANT	CONTRACTOR/INTERVAL
BP 01	1:20	ALPINE BIKE PARKS	1T
			REV. A

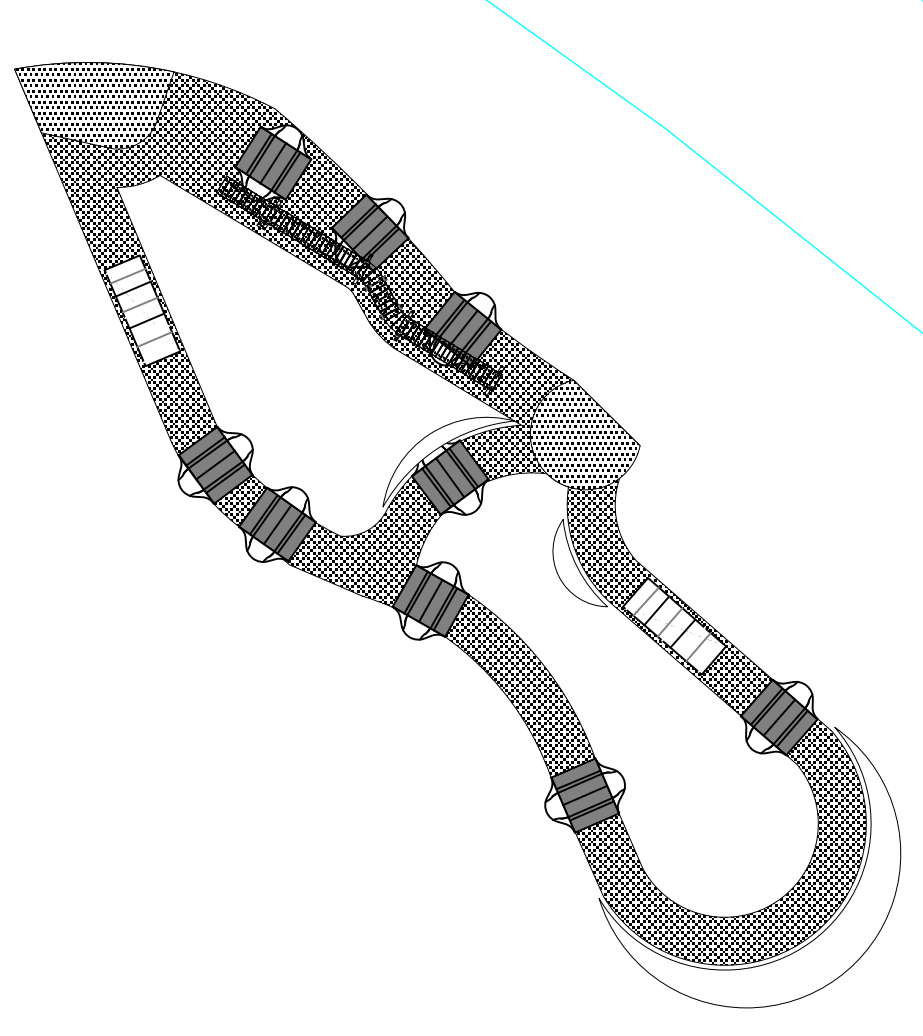
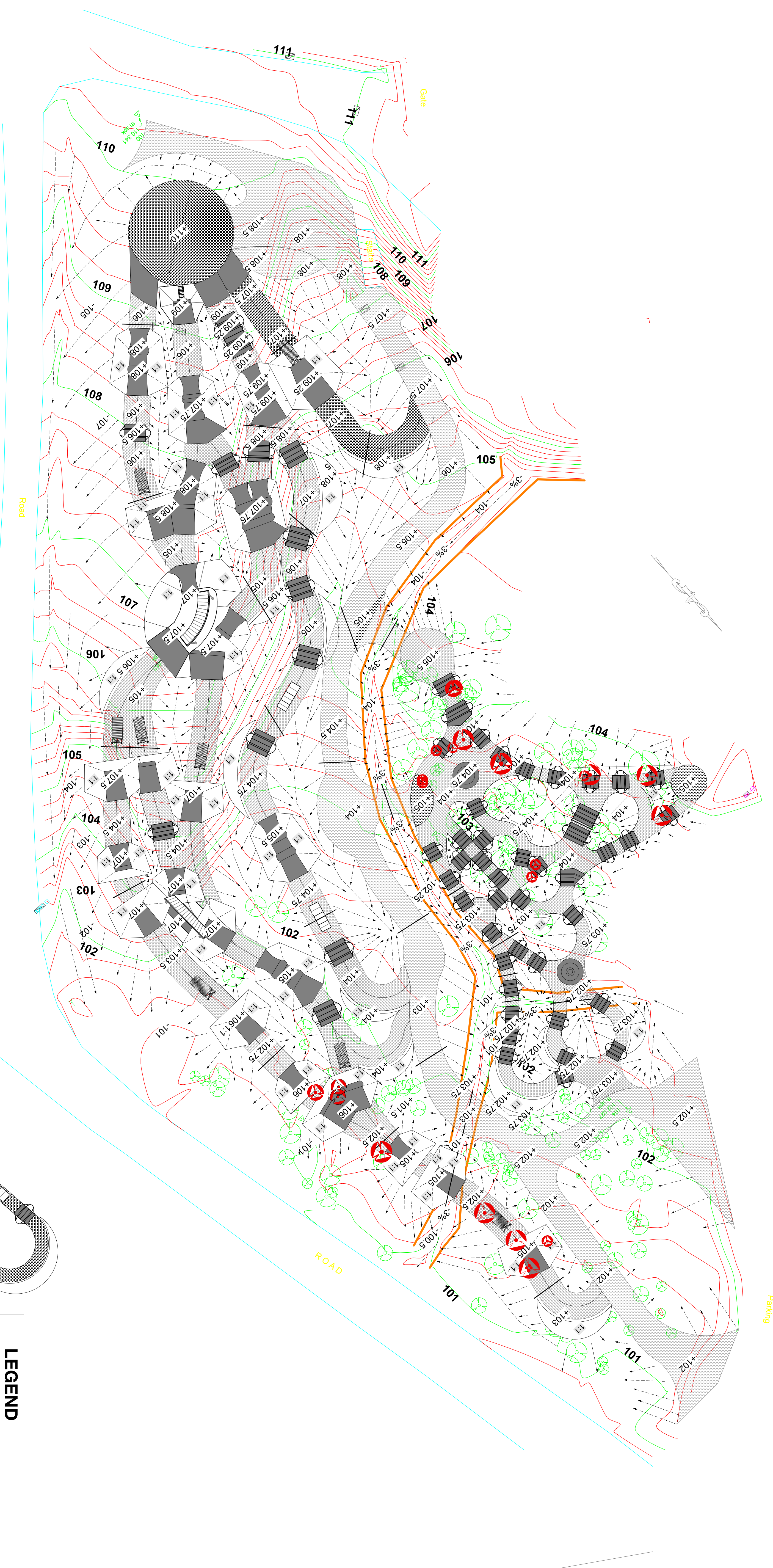

LEGEND

106	EXISTING ELEVATION
+106.5	PROPOSED ELEVATION
1/1	SIDE SLOPE
---	DRAINAGE PIPE
---	SHEET FLOW ARROW
ⓧ	DITCH EDGE
ⓧ	TREE TO FELL

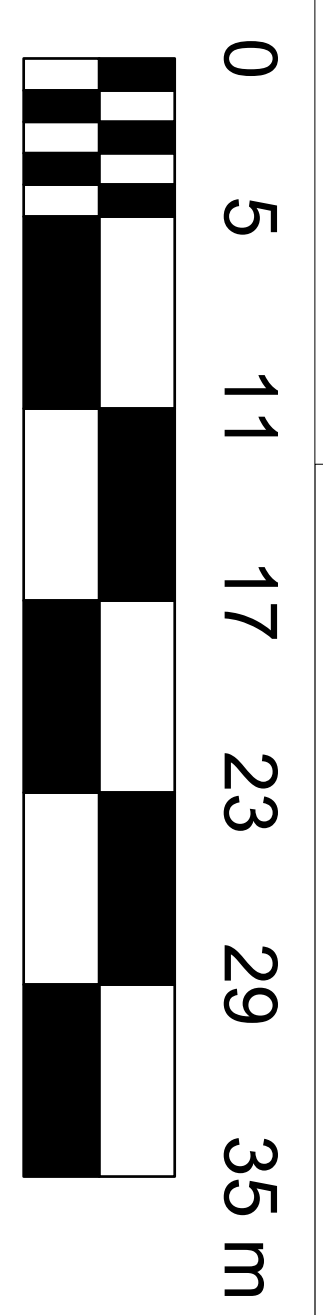

SHEET NUMBER	SCALE	CONSULTANT	CONTRACTOR/INTERVAL
BP 02	1:20	ALPINE BIKE PARKS	1/1
REV.			
A			

PROJECT
STEVIE SMITH BIKE PARK
 ROUGH GRADING

CONSULTANT
ALPINE BIKE PARKS CANADA
 455 W. Jolliffe Street
 Nanaimo, BC V9R 5A6

REVISIONS

REV.	DATE	DESCRIPTION	DESIGN	DRAFTING	REVIEW
D	16-08-22	DESIGN DEVELOPMENT	CI	CI	JD
C	16-08-02	FINAL CONCEPTUAL DESIGN	CI	CI	JD
B	16-06-18	CONCEPTUAL DESIGN DEVELOPMENT	CI	CI	JD
A	16-01-12	CONCEPTUAL DESIGN (V)	CI	CI	JD
		VY-AM-010	DESCRIPTION		

CLIENT
 City of Nanaimo
 455 W. Jolliffe Street
 Nanaimo, BC V9R 5A6

PROFESSIONAL STAMP
 NORTH ARROW

GENERAL NOTES
 Concept Design - NOT FOR CONSTRUCTION
 Final alignment of all trails identified to be determined during the detailed design phase by the successful consultant / contractor and approved owner's representative prior to construction.

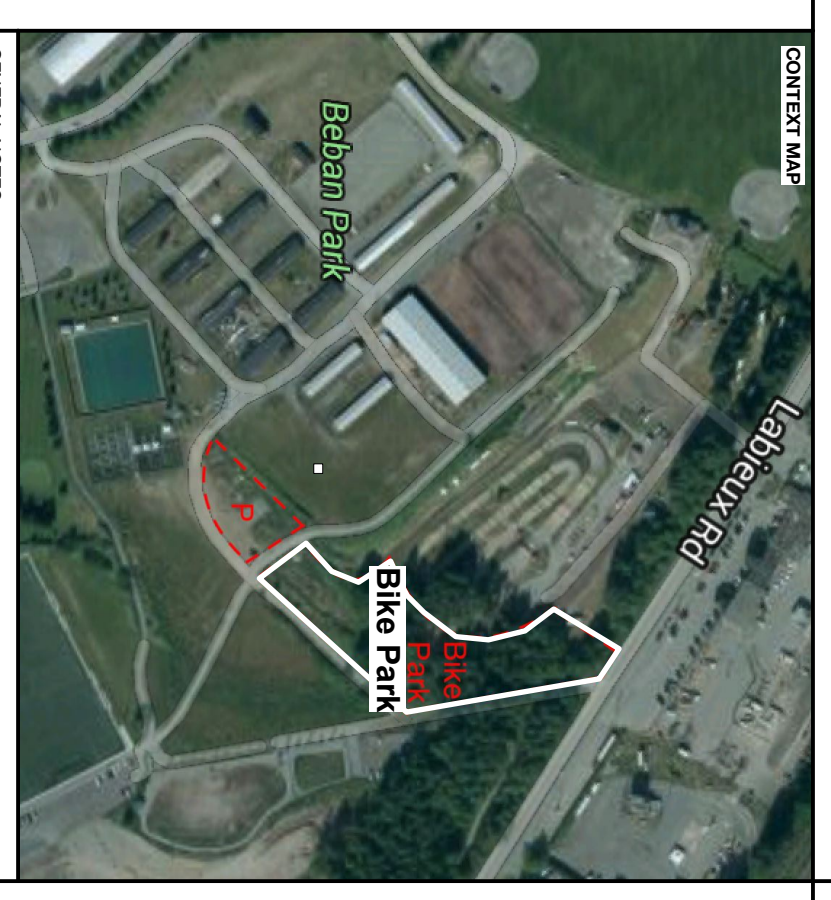

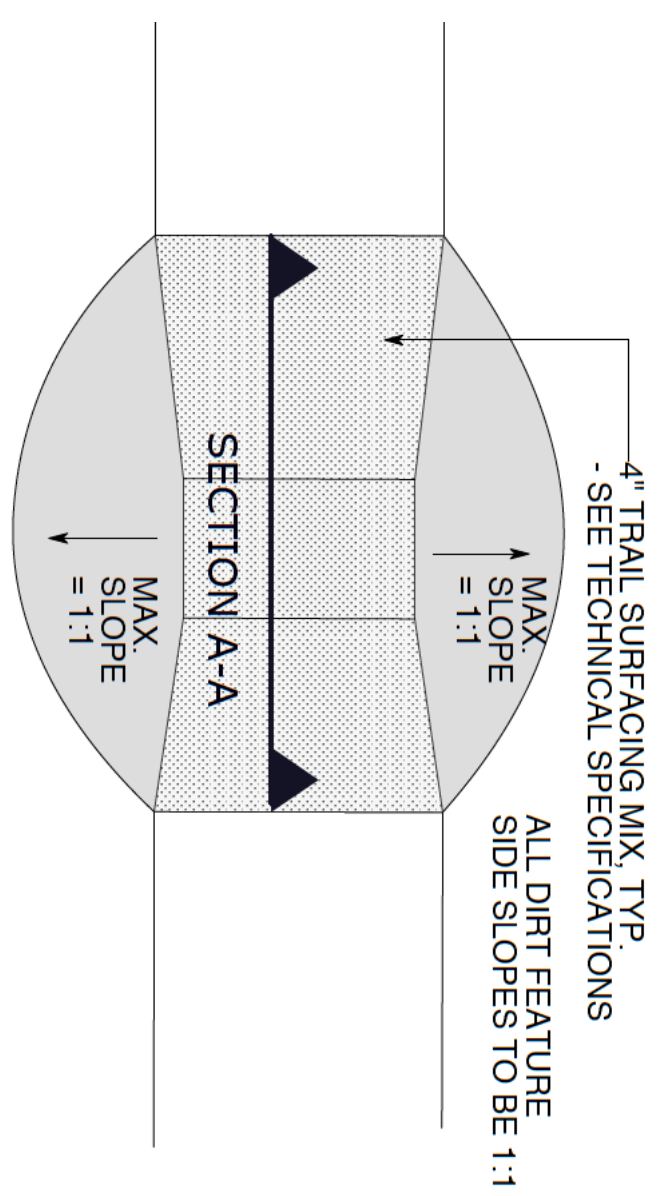

1 Roller - Plan Typ.

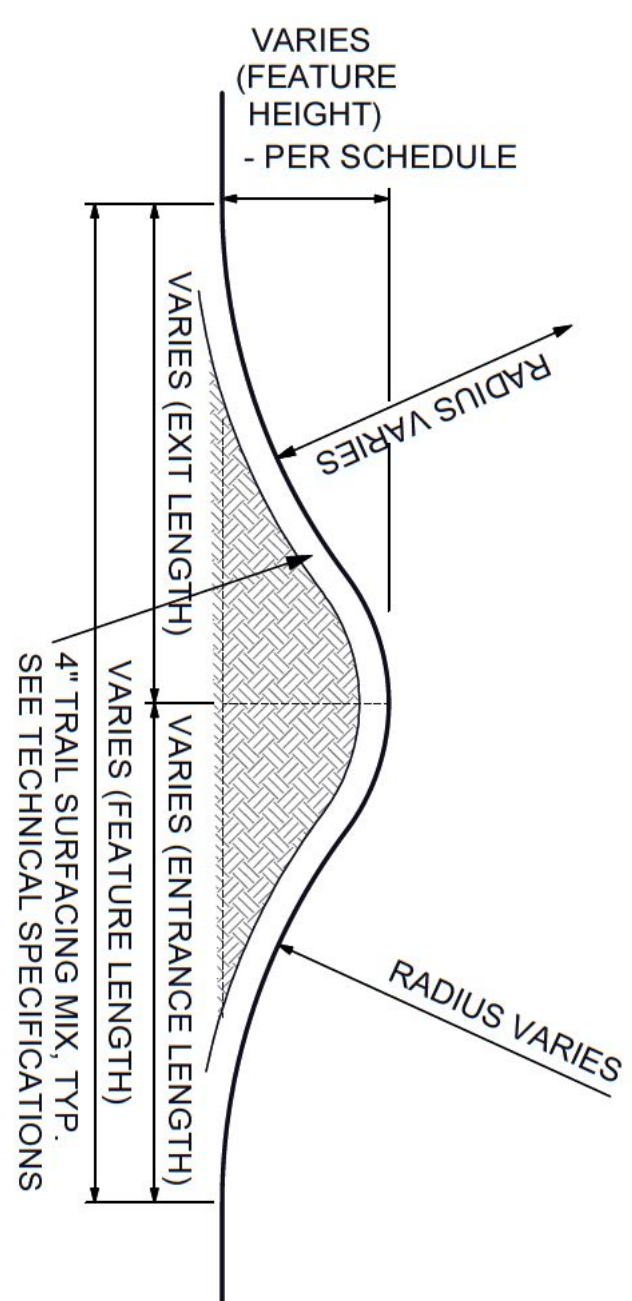

2 Roller - SECTION A

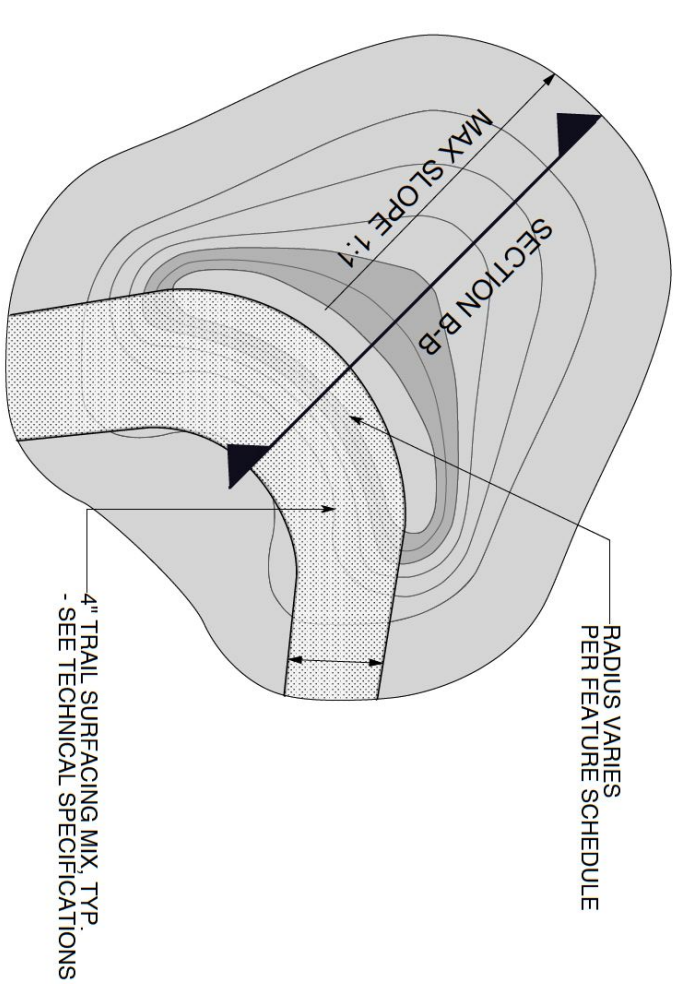

3 Berm - Plan Typ.

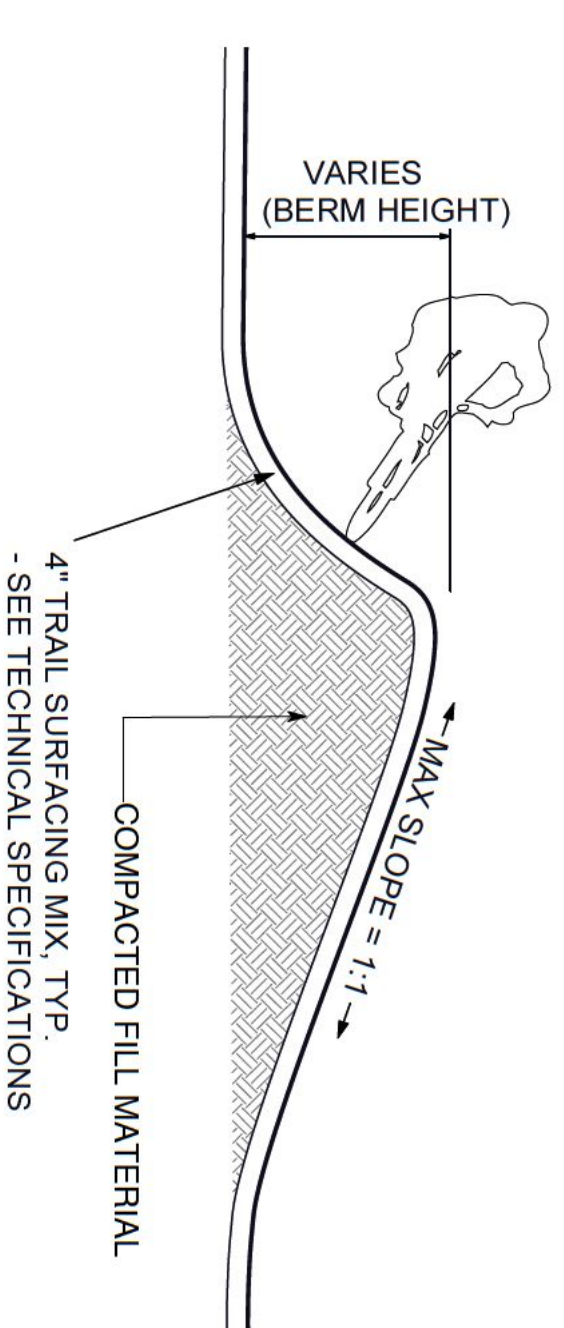

4 Berm - SECTION B

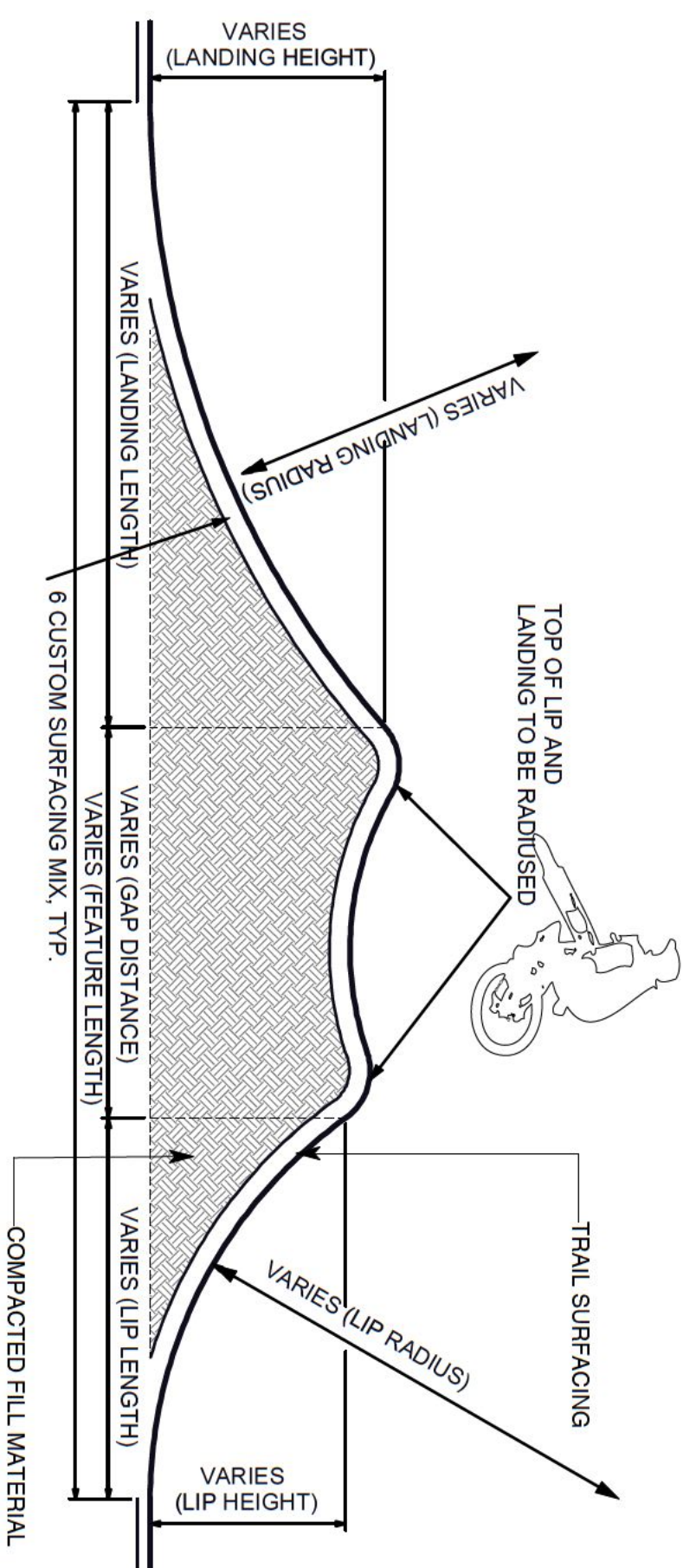

5 Roller Double Section Typ.

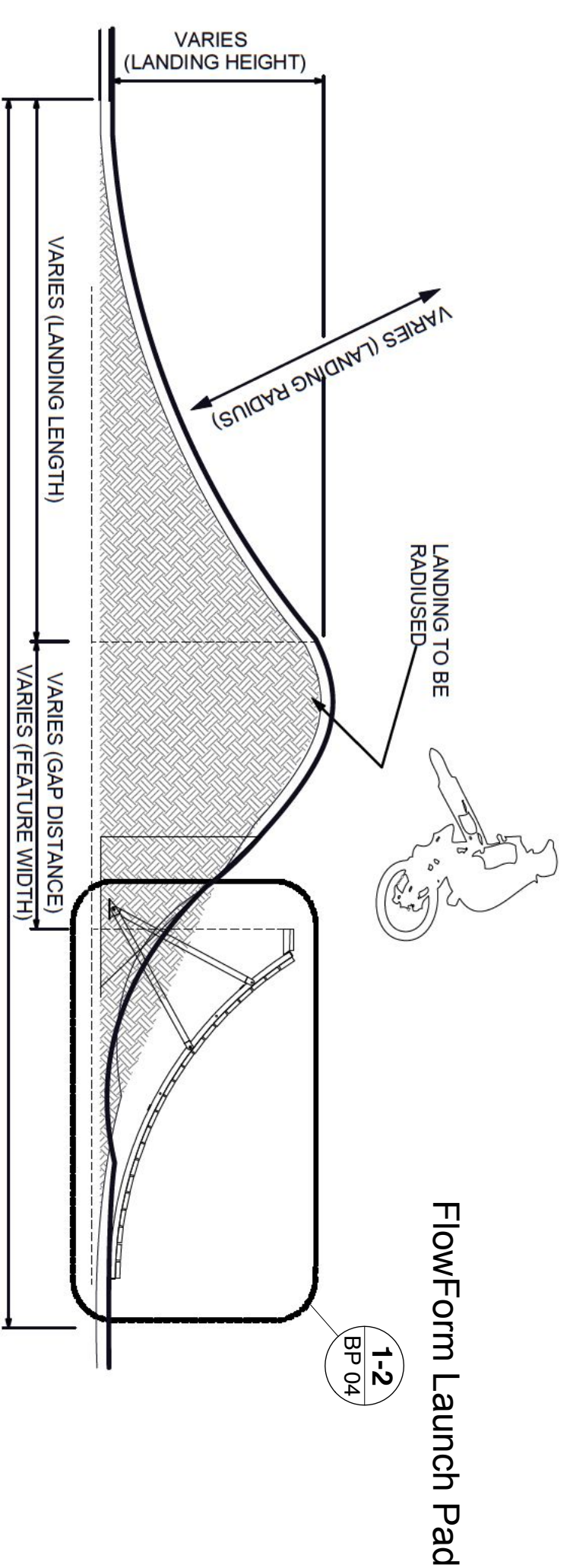

6 FlowForm Launch Pad with Dirt Landing

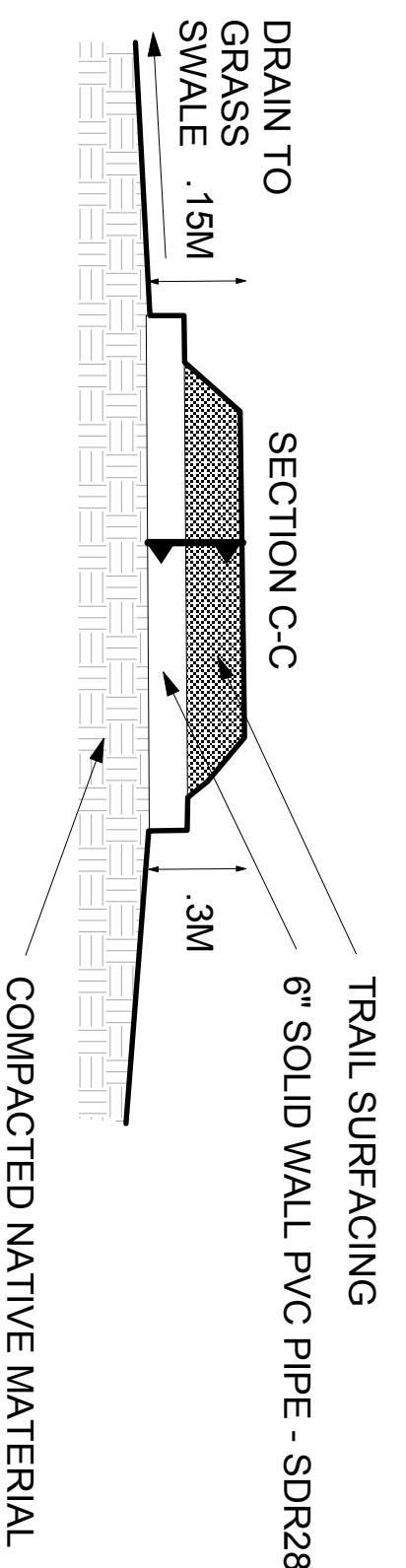

7 Drainage Pipe Under Trail - Plan Typ.

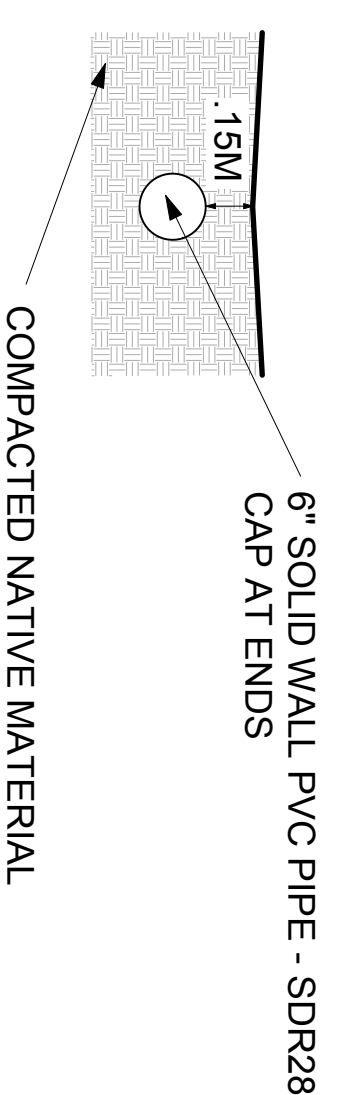

8 Drainage Pipe Under Trail - SECTION C

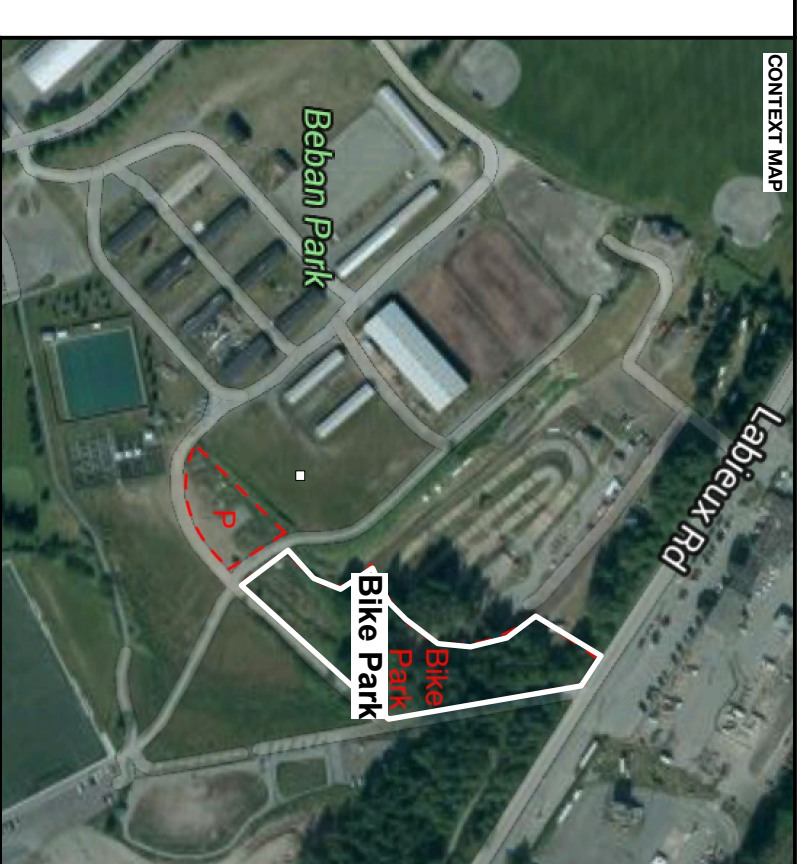

GENERAL NOTES
Concept Design - NOT FOR CONSTRUCTION
Final alignment of all trails identified to be determined during the detailed design phase by the successful consultant / contractor and approved owner's representative prior to construction.

PROFESSIONAL STAMP

NORTH ARROW

REV.	DATE	DESCRIPTION	DESIGN	DRAFTING	REVIEW
A	16-01-12	CONCEPTUAL DESIGN (I)	CI	CI	JD
B	16-06-18	CONCEPTUAL DESIGN DEVELOPMENT	CI	CI	JD
C	16-06-02	FINAL CONCEPTUAL DESIGN	CI	CI	JD
D	16-06-22	DESIGN DEVELOPMENT	CI	CI	JD

City of Nanaimo
455 Willinga Street
Nanaimo, BC V9R 5A6

ALPINE BIKE PARKS CANADA
1500-924-5690
1-800-924-5690
1-504-962-1951
www.alpinebikeparks.com

PROJECT
**STEVIE SMITH
BIKE PARK**

DRAWING TITLE
TYPICAL DETAILS

SHEET NUMBER
BP 03

SCALE
CONSULTANT
DRAWING NO.
REV.
A

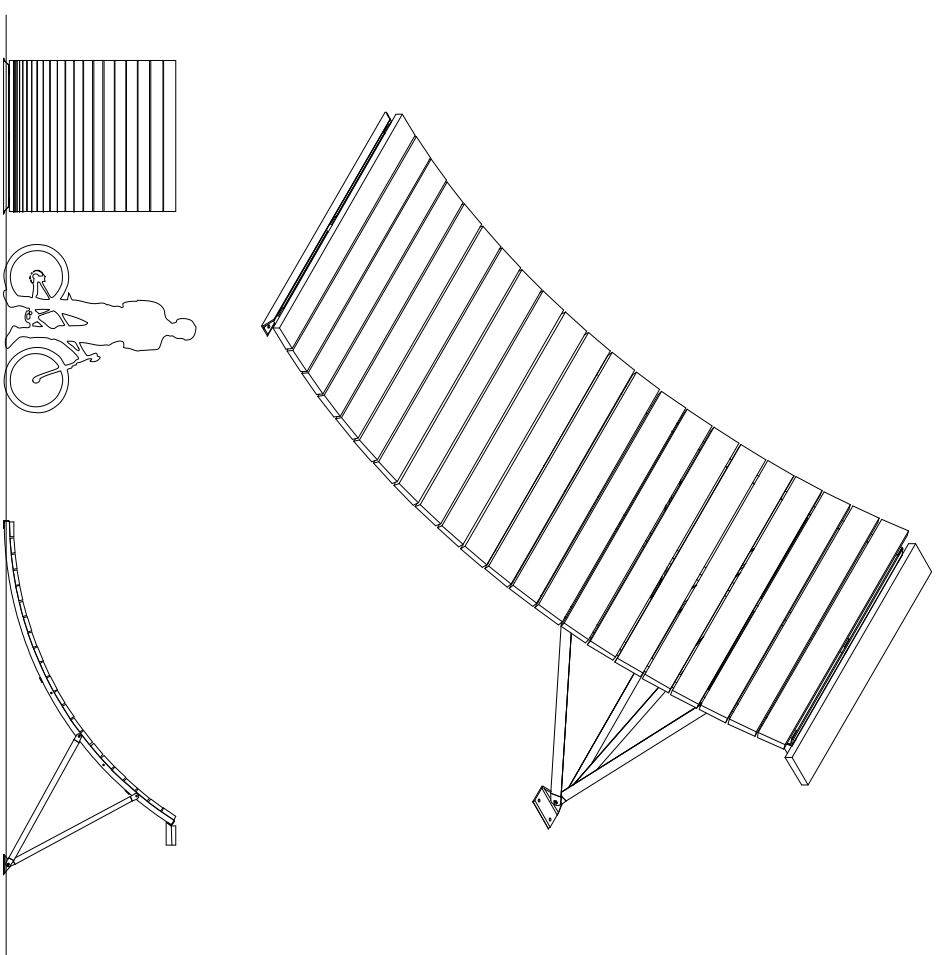

1 Launch Pad Feature (Medium)
by FlowForm Bike Ramps, Inc.

NTS

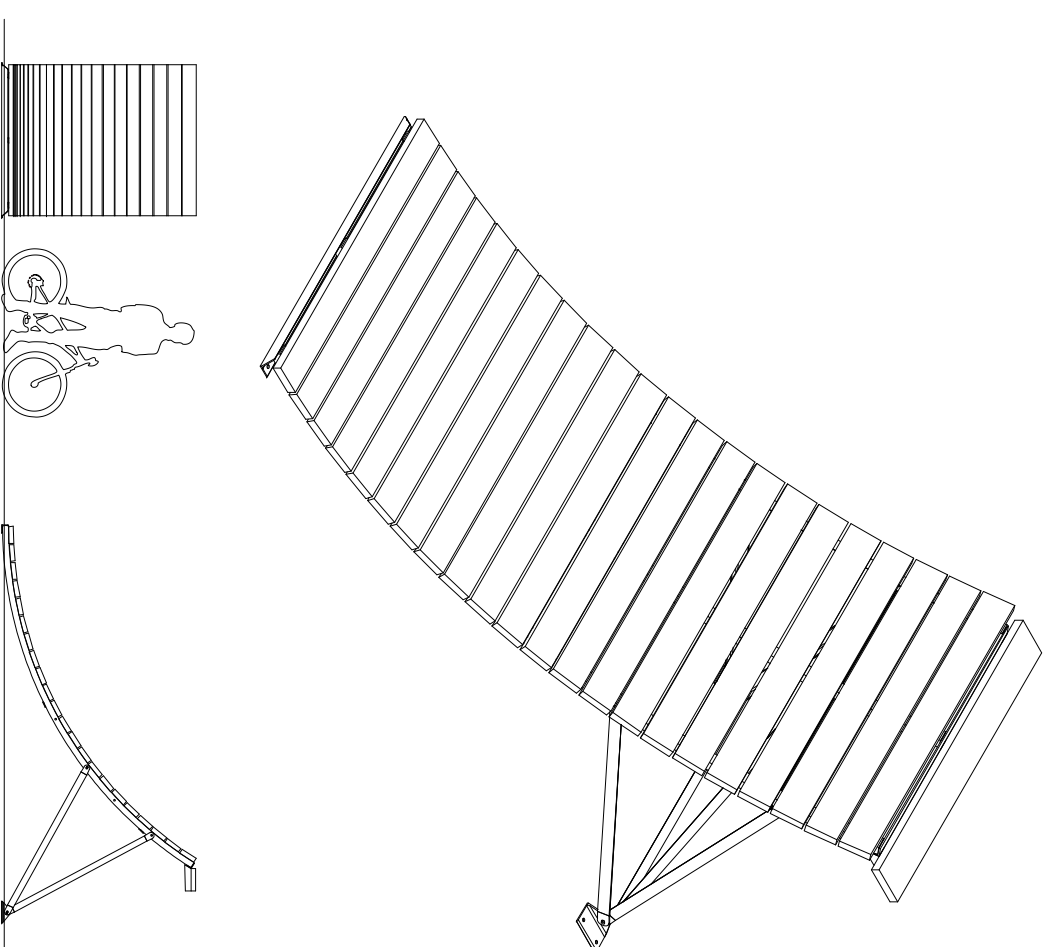

2 Launch Pad Feature (Large)
by FlowForm Bike Ramps, Inc.

NTS

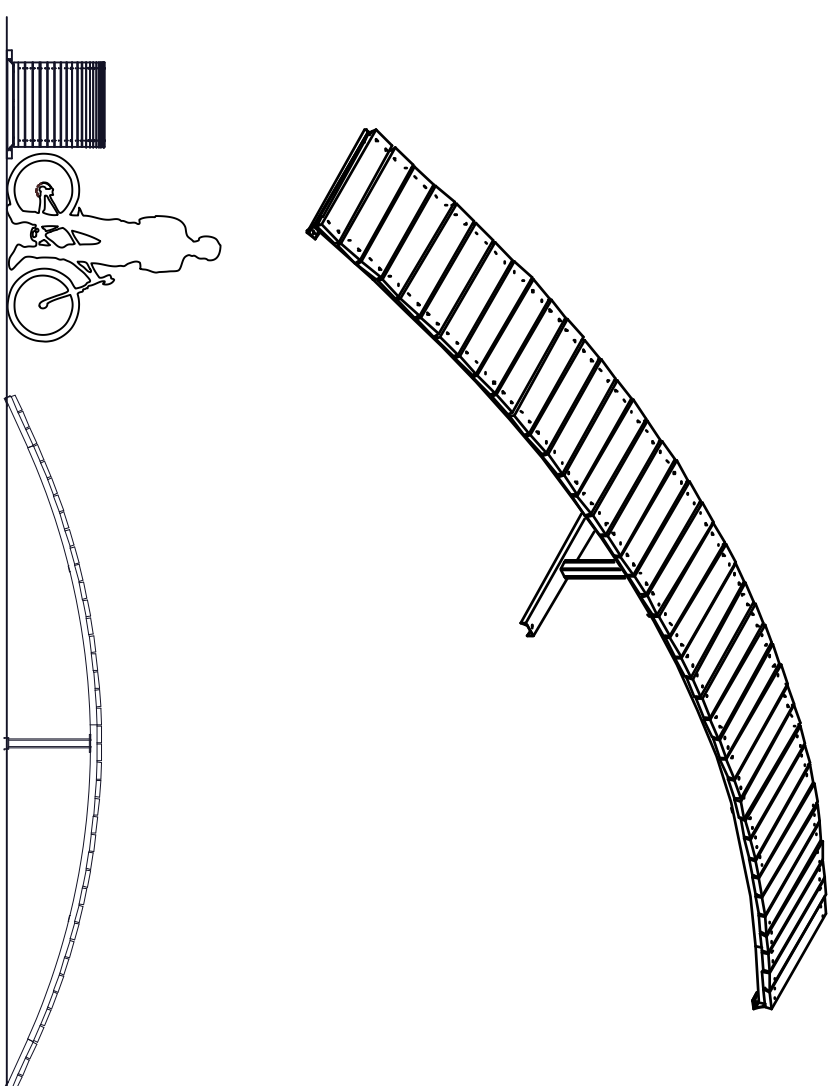

3 Rainbow Feature (Medium)
by FlowForm Bike Ramps, Inc.

NTS

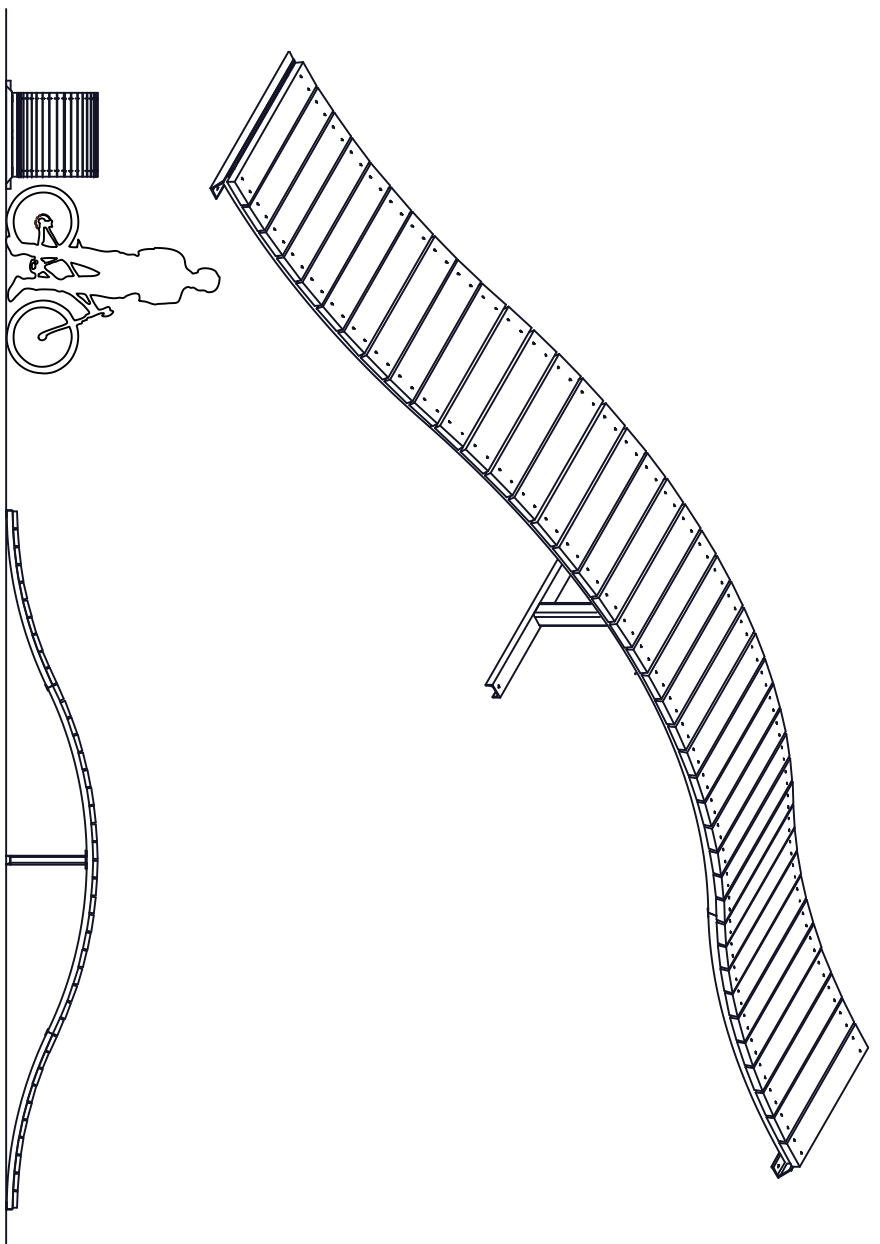

4 Sunset Feature (Medium)
by FlowForm Bike Ramps, Inc.

NTS

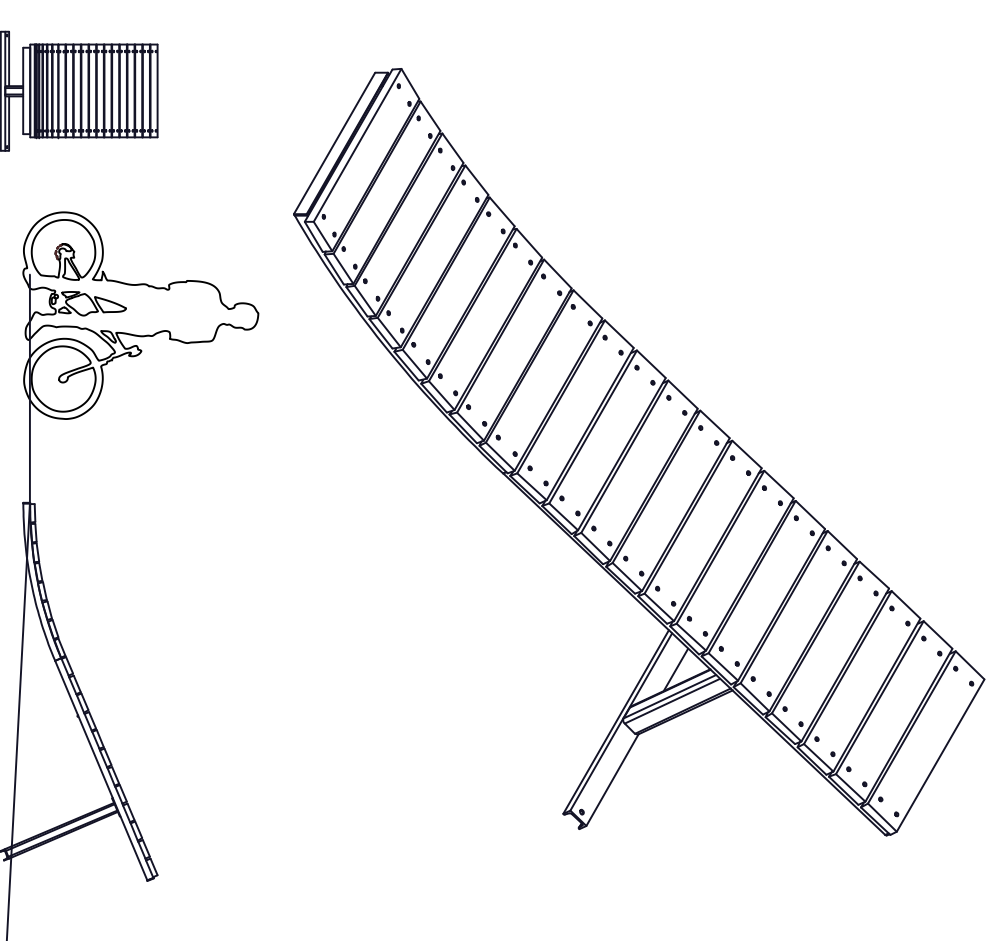

5 Cannon Feature (Small)
by FlowForm Bike Ramps, Inc.

NTS

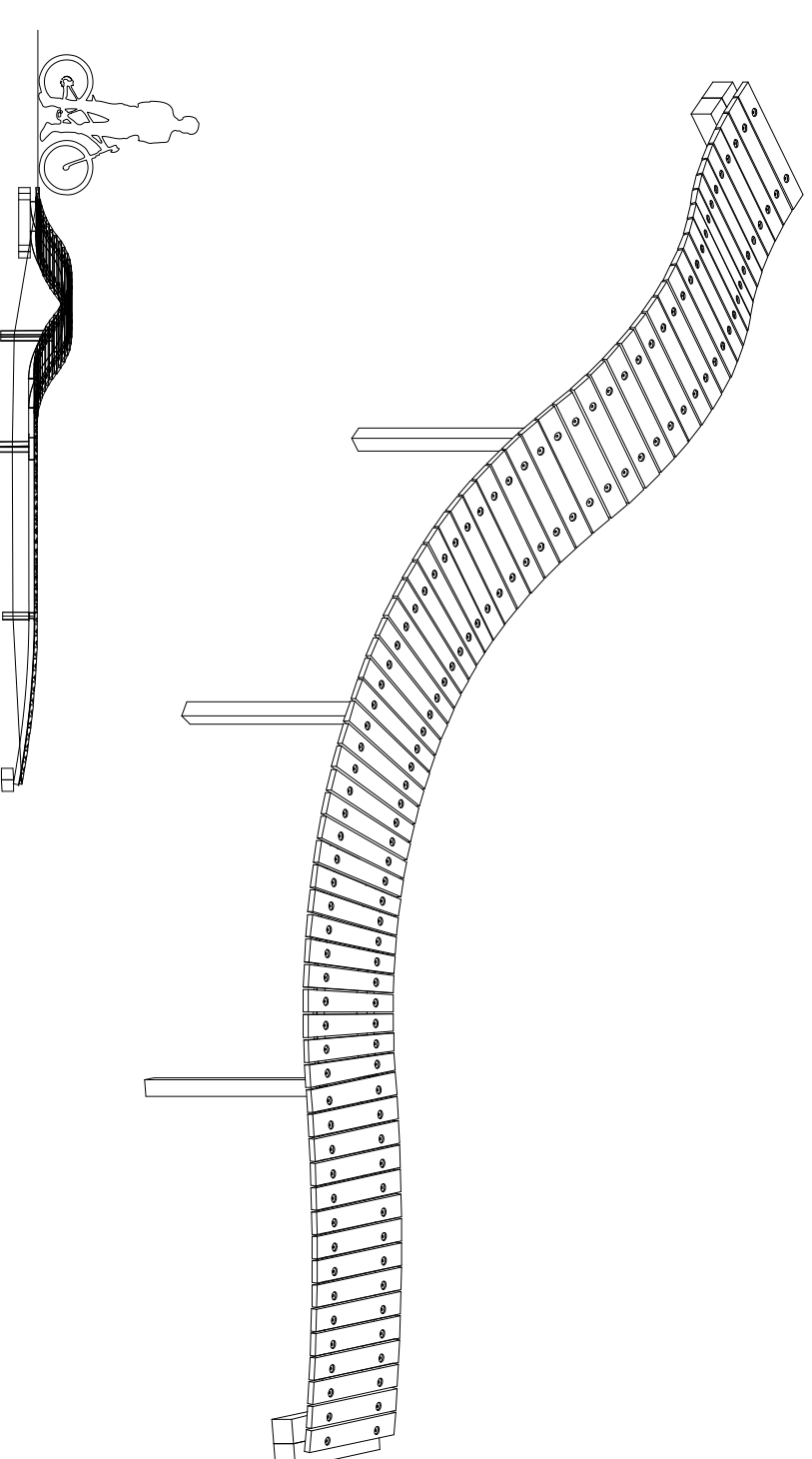

6 Shorebridge Feature
by FlowForm Bike Ramps, Inc.

NTS

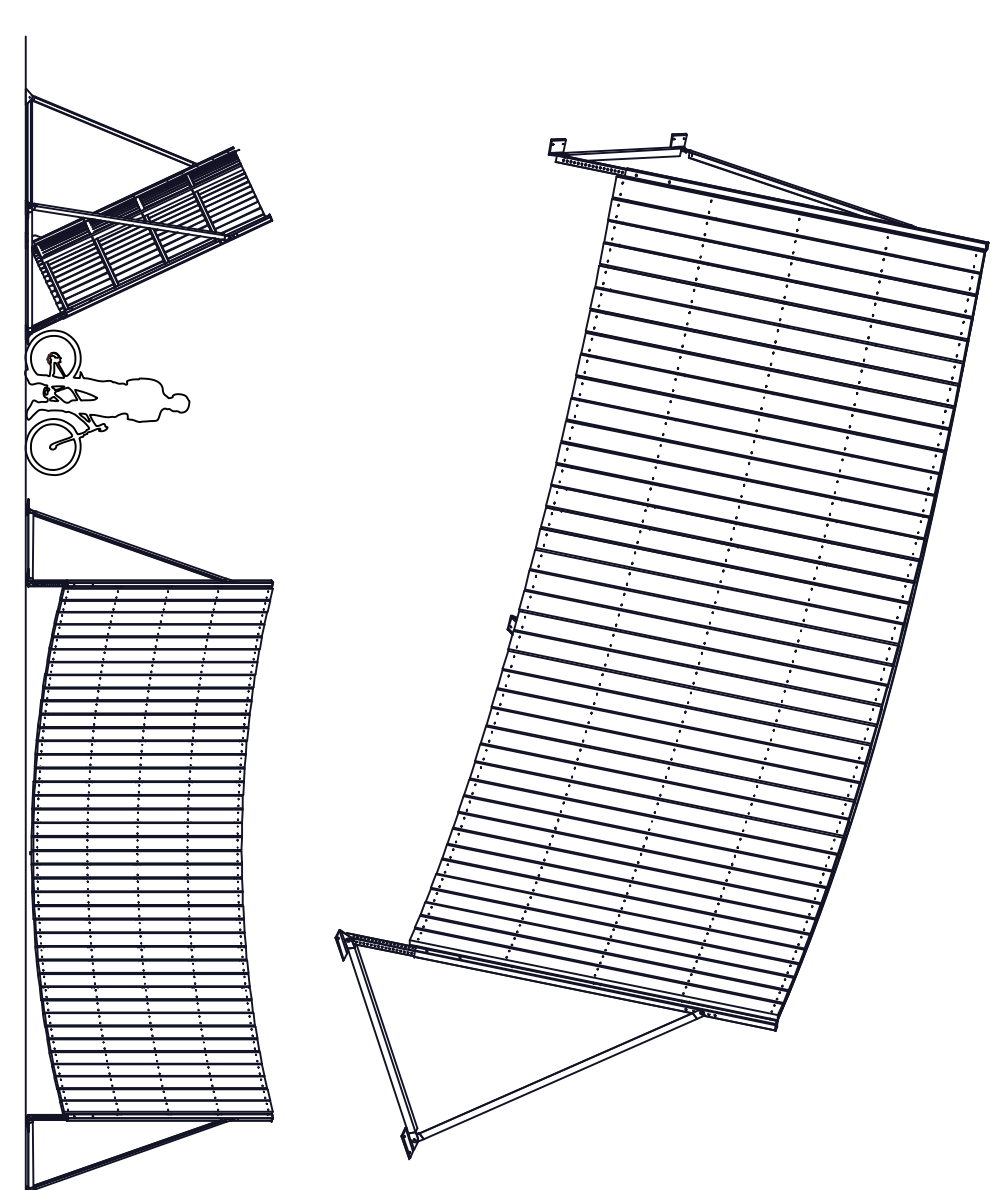

7 Curved Wall Feature (Medium)
by FlowForm Bike Ramps, Inc.

NTS

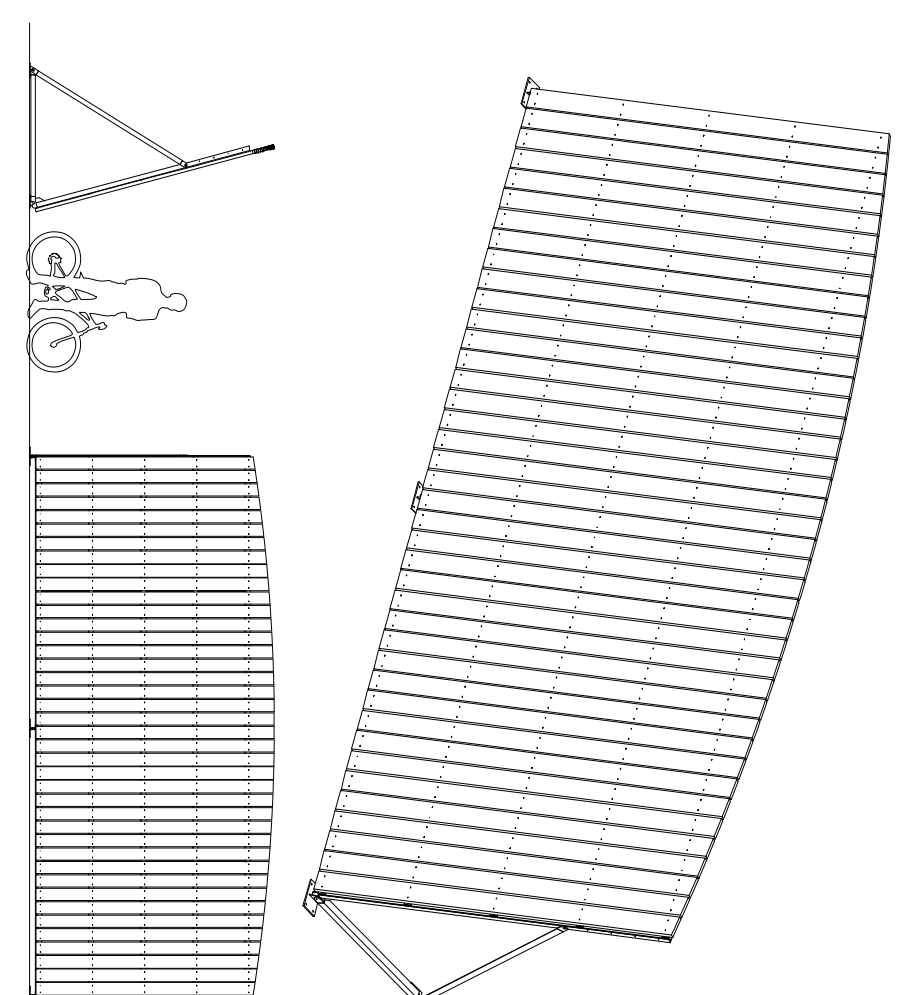

8 Flat Wallride Feature (Medium)
by FlowForm Bike Ramps, Inc.

NTS

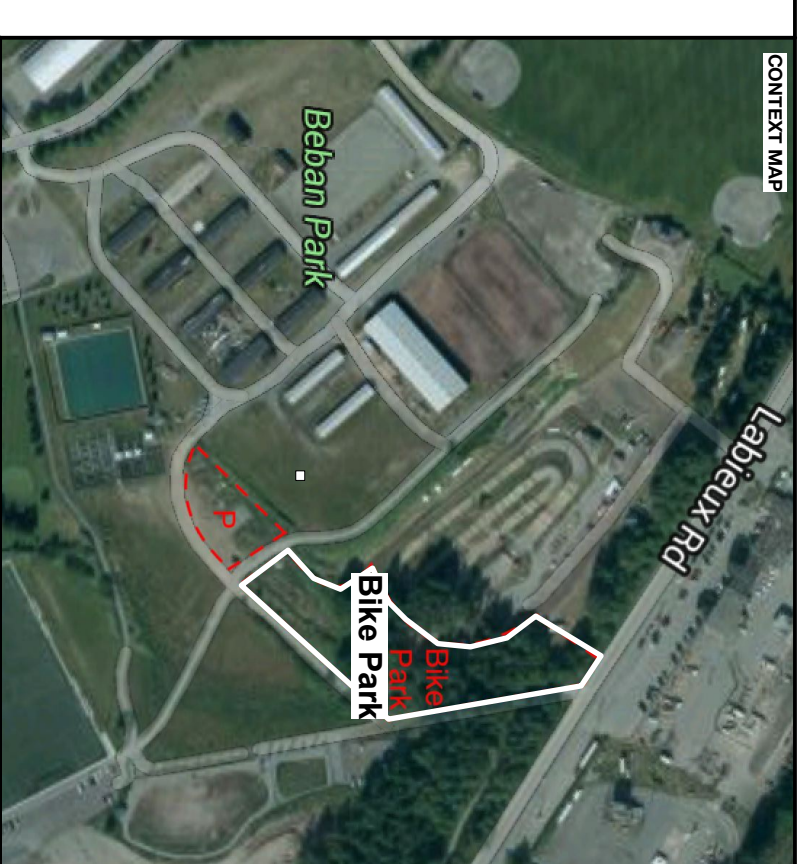

GENERAL NOTES
Concept Design - NOT FOR CONSTRUCTION
Final alignment of all trails identified to be determined during the detailed design phase by the successful consultant / contractor and approved owner's representative prior to construction.

PROFESSIONAL STAMP

NORTH ARROW

REV.	DATE	DESCRIPTION	DESIGN	DRAFTING	REVIEW
D	16-08-22	DESIGN DEVELOPMENT	CI	CI	JD
C	16-08-02	FINAL CONCEPTUAL DESIGN	CI	CI	JD
B	16-06-18	CONCEPTUAL DESIGN DEVELOPMENT	CI	CI	JD
A	16-01-12	CONCEPTUAL DESIGN (V1)	CI	CI	JD
REV.	Y:\M4100	DESCRIPTION			

Client
City of Nanaimo
455 Wallace Street
Nanaimo, BC V9R 5J6

CONSULTANT
ALPINE BIKE PARKS CANADA
1500-924-5690
1-800-924-5690
1-504-982-1951
www.alpinebikeparks.com

PROJECT
STEVIE SMITH BIKE PARK

DRAWING TITLE
TYPICAL FLOWFORM FEATURES

SHEET NUMBER
BP 04

SCALE	CONSULTANT DRAWING NO.	REV.
(CONTIGUOUS INTERVAL)		A

City of Nanaimo
 Bike Park Cost Estimate - Dirt Jumps, Return Trail and Pumptrack
 October 28, 2016

	Unit	Qty	Cost Per Unit	Cost
Construction Labour				
Rough Grade	Days	16	\$ 1,205.00	\$ 19,280.00
Complete Trail	Days	27	\$ 1,205.00	\$ 32,535.00
Drainage	Days	8	\$ 1,205.00	\$ 9,640.00
Features Install	Days	9	\$ 1,205.00	\$ 10,845.00
Total Construction Labour		60		\$ 72,300.00
Estimated Consulting Fees by Alpine Bike Parks (10 Trips)				
Estimated On-Site Consulting	Estimated Hours	100	\$ 130.00	\$ 13,000.00
Estimated Travel Hours	Estimated Hours	80	\$ 65.00	\$ 5,200.00
Estimated Off-Site Consulting	Estimated Hours	60	\$ 130.00	\$ 7,800.00
In-Town Fuel	Each	10	\$ 57.50	\$ 575.00
Per-Diems	Each	10	\$ 46.00	\$ 460.00
Hotel	Each	10	\$ 172.50	\$ 1,725.00
Mileage (250km round trip)	Each	10	\$ 158.70	\$ 1,587.00
Printing	Each	1	\$ 230.00	\$ 230.00
Ferry	Each	10	\$ 204.01	\$ 2,040.10
Total Consulting Fees				\$ 32,617.10
Materials				
Screened Surfacing Material (Screened On-Site)	Cubic Yards	420	\$ -	\$ -
3/4 Minus Crushed Road base 4" Thick	Cubic Yards	115	\$ 25.76	\$ 2,957.63
Cedar Boards	Board Feet	1500	\$ 2.30	\$ 3,450.00
Screws for Decking	Each	859	\$ 0.34	\$ 288.62
Anchors for Ramp Installation	Each	114	\$ 5.60	\$ 313.60
12' Trex for Ramp Decking Installation	Each	20	\$ 67.57	\$ 1,081.18
16' Trex for Ramp Decking Installation	Each	4	\$ 91.08	\$ 1,081.18
Concrete Pre-Cast Footings	Each	12	\$ 126.50	\$ 1,518.00
Concrete Cast-In Place Footings	Cubic Yards	16	\$ 345.00	\$ 5,520.00
6" Drain Pipe (Schedule 40)	3 meter sections	30	\$ 53.72	\$ 1,611.46
Dirt Fill For Features	Cubic Yards	3050	\$ -	\$ -
Min Excavator Including Fuel	Months	3	\$ 6,037.05	\$ 18,111.14
Skid Steer Including Fuel	Months	3	\$ 5,738.44	\$ 17,215.32
Plate Compactor Including Fuel	Months	3	\$ 1,333.00	\$ 3,999.00
Quad Rental Including Fuel	Months	3	\$ 1,188.54	\$ 3,565.61
Screen Plant Including Fuel	Months	1	\$ 3,000.00	\$ 3,000.00
4 CY Loader Including Fuel	Week	1	\$ 3,000.00	\$ 3,000.00
Extra Piece of Equipment Including Fuel	Months	3	\$ 3,829.22	\$ 11,487.66
Miscellaneous Tools/Supplies	Lump Sum	1	\$ 2,104.50	\$ 2,104.50
Mulch for Mulch Jump	Cubic Yards	50	\$ 28.75	\$ 1,437.50
Landscape and Irrigation Estimate	Estimate	1	\$ 43,500.00	\$ 43,500.00
Total Material Costs				\$ 125,242.40
FlowForm Features				
Curved Wall Ride (8ft)	Each	1	\$ 8,778.56	\$ 8,778.56
Flat Wall Ride (8ft)	Each	1	\$ 8,778.56	\$ 8,778.56
Launch Pad Large	Each	5	\$ 3,242.55	\$ 16,212.76
Launch Pad Medium	Each	4	\$ 2,979.20	\$ 11,916.80
Total FlowForm Costs				\$ 45,686.68
Grand Total				\$ 275,846

City of Nanaimo
Bike Park Materials List - Dirt Jumps, Return Trail and Pumptrack
October 28, 2016

Item		Specification	Unit	Quantity	
Fill and Drainage					
Screened Surfacing Material (Screened On-Site)		NA	Cubic Yards	420	
3/4 Minus Crushed Road base 4" Thick		NA	Cubic Yards	115	
Mulch for Mulch Jump		NA	Cubic Yards	50	
6" Drain Pipe in 3 meter Sections (Schedule 40)		Corix - 6" SDR28	Each	30	
Dirt Fill For Features (Sourced On-Site)		NA	Cubic Yards	3,050	
Ramp Decking - Cedar Boards S1S2E (1 smooth side, 2 edges)					
56" Board	Cedar	S1S2E	Boards	163	
118.22" Board	Cedar	S1S2E	Boards	72	
Screws and Trex for FlowForm Decking					
2.5" GRK Screw		NA	Each	859	
12' Trex Composite Decking		NA	Each	20	
16' Trex Composite Decking		NA	Each	4	
Bolts for FlowForm Installation					
Stainless Steel	1/2" x 7" Expansion Anchor bolt with washer, nut		MC Master #92188A303	Each	114
Concrete Pre-Cast Footings					
Concrete	Full Size Flat Top		Lock Block	Each	-
Concrete	Half Height Flat Top		Lock Block	Each	-
Concrete	Half-Height Half Flat Top		Lock Block	Each	12
Concrete Cast-In Place Footings					
Poured Concrete	Form Dimensions: 2'W x 1'D x 12'L		18 Forms	Cubic Yards	16.0
Ramp Frames					
Curved Wall Ride (8ft)		FlowForm	Each	1.00	
Flat Wall Ride (8ft)		FlowForm	Each	1.00	
Launch Pad Large		FlowForm	Each	5.00	
Launch Pad Medium		FlowForm	Each	4.00	
Equipment					
Min Excavator Including Fuel		NA	Months	3	
Skid Steer Including Fuel		NA	Months	3	
Plate Compactor Including Fuel		NA	Months	3	
Quad Rental Including Fuel		NA	Months	3	
Screen Plant Including Fuel		NA	Months	1	
4 CY Loader Including Fuel		NA	Week	1	
Extra Piece of Equipment Including Fuel		NA	Months	3	

City of Nanaimo
Bike Park Cost Estimate - Pumptrack Only
October 28, 2016

	Unit	Qty	Cost Per Unit	Cost
Construction Labour				
Rough Grade	Days	3	\$ 1,205.00	\$ 3,615.00
Complete Trail	Days	9	\$ 1,205.00	\$ 10,845.00
Drainage	Days	2	\$ 1,205.00	\$ 2,410.00
Total Construction Labour		14		\$ 16,870.00
Estimated Consulting Fees by Alpine Bike Parks (2 Trips)				
Estimated On-Site Consulting	Estimated Hours	20	\$ 130.00	\$ 2,600.00
Estimated Travel Hours	Estimated Hours	16	\$ 65.00	\$ 1,040.00
Estimated Off-Site Consulting	Estimated Hours	12	\$ 130.00	\$ 1,560.00
In-Town Fuel	Each	2	\$ 57.50	\$ 115.00
Per-Diems	Each	2	\$ 46.00	\$ 92.00
Hotel	Each	2	\$ 172.50	\$ 345.00
Mileage (250km round trip)	Each	2	\$ 158.70	\$ 317.40
Printing	Each	1	\$ 230.00	\$ 230.00
Ferry	Each	2	\$ 204.01	\$ 408.02
Total Consulting Fees				\$ 6,707.42
Materials				
Screened Surfacing Material (Screened On-Site)	Cubic Yards	120	\$ -	\$ -
6" Drain Pipe (Schedule 40)	3 meter sections	15	\$ 53.72	\$ 805.73
Dirt Fill For Features	Cubic Yards	800	\$ -	\$ -
Min Excavator Including Fuel	Months	1	\$ 6,037.05	\$ 6,037.05
Skid Steer Including Fuel	Months	1	\$ 5,738.44	\$ 5,738.44
Plate Compactor Including Fuel	Months	1	\$ 1,333.00	\$ 1,333.00
Quad Rental Including Fuel	Months	1	\$ 1,188.54	\$ 1,188.54
Screen Plant Including Fuel	Months	0	\$ 3,000.00	\$ -
4 CY Loader Including Fuel	Week	0	\$ 3,000.00	\$ -
Extra Piece of Equipment Including Fuel	Months	1	\$ 3,829.22	\$ 3,829.22
Miscellaneous Tools/Supplies	Lump Sum	1	\$ 483.00	\$ 483.00
Landscape and Irrigation Estimate	Estimate	0	\$ 43,500.00	\$ -
Total Material Costs				\$ 19,414.97
Grand Total				\$ 42,992

City of Nanaimo
 Bike Park Materials List - Pumptrack Only
 October 28, 2016

Item	Specification	Unit	Quantity
Fill and Drainage			
Screened Surfacing Material (Screened On-Site)	NA	Cubic Yards	120
6" Drain Pipe in 3 meter Sections (Schedule 40)	Corix - 6" SDR28	Each	15
Dirt Fill For Features (Sourced On-Site)	NA	Cubic Yards	800
Equipment			
Min Excavator Including Fuel	NA	Months	1
Skid Steer Including Fuel	NA	Months	1
Plate Compactor Including Fuel	NA	Months	1
Quad Rental Including Fuel	NA	Months	1
Extra Piece of Equipment Including Fuel	NA	Months	1

City of Nanaimo
Bike Park Cost Estimate - Dirt Jumps and Return Trail Only
October 28, 2016

	Unit	Qty	Cost Per Unit	Cost
Construction Labour				
Rough Grade	Days	13	\$ 1,205.00	\$ 15,665.00
Complete Trail	Days	18	\$ 1,205.00	\$ 21,690.00
Drainage	Days	6	\$ 1,205.00	\$ 7,230.00
Features Install	Days	9	\$ 1,205.00	\$ 10,845.00
Total Construction Labour		46		\$ 55,430.00
Estimated Consulting Fees by Alpine Bike Parks (8 Trips)				
Estimated On-Site Consulting	Estimated Hours	80	\$ 130.00	\$ 10,400.00
Estimated Travel Hours	Estimated Hours	64	\$ 65.00	\$ 4,160.00
Estimated Off-Site Consulting	Estimated Hours	48	\$ 130.00	\$ 6,240.00
In-Town Fuel	Each	8	\$ 57.50	\$ 460.00
Per-Diems	Each	8	\$ 46.00	\$ 368.00
Hotel	Each	8	\$ 172.50	\$ 1,380.00
Mileage (250km round trip)	Each	8	\$ 158.70	\$ 1,269.60
Printing	Each	1	\$ 230.00	\$ 230.00
Ferry	Each	8	\$ 204.01	\$ 1,632.08
Total Consulting Fees				\$ 26,139.68
Materials				
Screened Surfacing Material (Screened On-Site)	Cubic Yards	300	\$ -	\$ -
3/4 Minus Crushed Road base 4" Thick	Cubic Yards	115	\$ 25.76	\$ 2,957.63
Cedar Boards	Board Feet	1500	\$ 2.30	\$ 3,450.00
Screws for Decking	Each	859	\$ 0.34	\$ 288.62
Anchors for Ramp Installation	Each	114	\$ 5.60	\$ 313.60
12' Trex for Ramp Decking Installation	Each	20	\$ 67.57	\$ 1,081.18
16' Trex for Ramp Decking Installation	Each	4	\$ 91.08	\$ 1,081.18
Concrete Pre-Cast Footings	Each	12	\$ 126.50	\$ 1,518.00
Concrete Cast-In Place Footings	Cubic Yards	16	\$ 345.00	\$ 5,520.00
6" Drain Pipe (Schedule 40)	3 meter sections	15	\$ 53.72	\$ 805.73
Dirt Fill For Features	Cubic Yards	2250	\$ -	\$ -
Min Excavator Including Fuel	Months	2	\$ 6,037.05	\$ 12,074.09
Skid Steer Including Fuel	Months	2	\$ 5,738.44	\$ 11,476.88
Plate Compactor Including Fuel	Months	2	\$ 1,333.00	\$ 2,666.00
Quad Rental Including Fuel	Months	2	\$ 1,188.54	\$ 2,377.07
Screen Plant Including Fuel	Months	1	\$ 3,000.00	\$ 3,000.00
4 CY Loader Including Fuel	Week	1	\$ 3,000.00	\$ 3,000.00
Extra Piece of Equipment Including Fuel	Months	2	\$ 3,829.22	\$ 7,658.44
Miscellaneous Tools/Supplies	Lump Sum	1	\$ 1,621.50	\$ 1,621.50
Mulch for Mulch Jump	Cubic Yards	50	\$ 28.75	\$ 1,437.50
Landscape and Irrigation Estimate	Estimate	1	\$ 43,500.00	\$ 43,500.00
Total Material Costs				\$ 105,827.43
FlowForm Features				
Curved Wall Ride (8ft)	Each	1	\$ 8,778.56	\$ 8,778.56
Flat Wall Ride (8ft)	Each	1	\$ 8,778.56	\$ 8,778.56
Launch Pad Large	Each	5	\$ 3,242.55	\$ 16,212.76
Launch Pad Medium	Each	4	\$ 2,979.20	\$ 11,916.80
Total FlowForm Costs				\$ 45,686.68
Grand Total				\$ 233,084

City of Nanaimo
 Bike Park Materials List - Dirt Jumps and Return Trail Only
 October 28, 2016

Item		Specification	Unit	Quantity
Fill and Drainage				
Screened Surfacing Material (Screened On-Site)		NA	Cubic Yards	300
3/4 Minus Crushed Road base 4" Thick		NA	Cubic Yards	115
Mulch for Mulch Jump		NA	Cubic Yards	50
6" Drain Pipe in 3 meter Sections (Schedule 40)		Corix - 6" SDR28	Each	15
Dirt Fill For Features (Sourced On-Site)		NA	Cubic Yards	2,250
Ramp Decking - Cedar Boards S1S2E (1 smooth side, 2 edges)				
56" Board	Cedar	S1S2E	Boards	163
118.22" Board	Cedar	S1S2E	Boards	72
Screws and Trex for FlowForm Decking				
2.5" GRK Screw		NA	Each	859
12' Trex Composite Decking		NA	Each	20
16' Trex Composite Decking		NA	Each	4
Bolts for FlowForm Installation				
Stainless Steel	1/2" x 7" Expansion Anchor bolt with washer, nut	MC Master #92188A303	Each	114
Concrete Pre-Cast Footings				
Concrete	Half-Height Half Flat Top	Lock Block	Each	12
Concrete Cast-In Place Footings				
Poured Concrete	Form Dimensions: 2'W x 1'D x 12'L	18 Forms	Cubic Yards	16
Ramp Frames				
Curved Wall Ride (8ft)		FlowForm	Each	1
Flat Wall Ride (8ft)		FlowForm	Each	1
Launch Pad Large		FlowForm	Each	5
Launch Pad Medium		FlowForm	Each	4
Equipment				
Min Excavator Including Fuel		NA	Months	2
Skid Steer Including Fuel		NA	Months	2
Plate Compactor Including Fuel		NA	Months	2
Quad Rental Including Fuel		NA	Months	2
Screen Plant Including Fuel		NA	Months	1
4 CY Loader Including Fuel		NA	Week	1
Extra Piece of Equipment Including Fuel		NA	Months	2

City of Nanaimo
Bike Park Cost Estimate - Skills Trail Only
October 28, 2016

	Unit	Qty	Cost Per Unit	Cost
Construction Labour				
Rough Grade	Days	2	\$ 1,205.00	\$ 2,410.00
Complete Trail	Days	4	\$ 1,205.00	\$ 4,820.00
Drainage	Days	1	\$ 1,205.00	\$ 1,205.00
Features Install	Days	5	\$ 1,205.00	\$ 6,025.00
Total Construction Labour		12		\$ 14,460.00
Estimated Consulting Fees by Alpine Bike Parks (2 Trips)				
Estimated On-Site Consulting	Estimated Hours	20	\$ 130.00	\$ 2,600.00
Estimated Travel Hours	Estimated Hours	16	\$ 65.00	\$ 1,040.00
Estimated Off-Site Consulting	Estimated Hours	12	\$ 130.00	\$ 1,560.00
In-Town Fuel	Each	2	\$ 57.50	\$ 115.00
Per-Diems	Each	2	\$ 46.00	\$ 92.00
Hotel	Each	2	\$ 172.50	\$ 345.00
Mileage (250km round trip)	Each	2	\$ 158.70	\$ 317.40
Printing	Each	1	\$ 230.00	\$ 230.00
Ferry	Each	2	\$ 204.01	\$ 408.02
Total Consulting Fees				\$ 6,707.42
Materials				
Screened Surfacing Material (Screened On-Site)	Cubic Yards	60	\$ -	\$ -
3/4 Minus Crushed Road base 4" Thick	Cubic Yards	-	\$ 25.76	\$ -
Cedar Boards	Board Feet	352	\$ 2.30	\$ 809.60
Screws for Decking	Each	262	\$ 0.34	\$ 88.03
Anchors for Ramp Installation	Each	56	\$ 5.60	\$ 313.60
12' Trex for Ramp Decking Installation	Each	16	\$ 67.57	\$ 1,081.18
Concrete Pre-Cast Footings	Each	24	\$ 126.50	\$ 3,036.00
6" Drain Pipe (Schedule 40)	3 meter sections	8	\$ 53.72	\$ 429.72
Dirt Fill For Features	Cubic Yards	500	\$ -	\$ -
Min Excavator Including Fuel	Months	1	\$ 6,037.05	\$ 6,037.05
Skid Steer Including Fuel	Months	1	\$ 5,738.44	\$ 5,738.44
Plate Compactor Including Fuel	Months	1	\$ 1,333.00	\$ 1,333.00
Quad Rental Including Fuel	Months	1	\$ 1,188.54	\$ 1,188.54
Screen Plant Including Fuel	Months	0.25	\$ 3,000.00	\$ 750.00
4 CY Loader Including Fuel	Week	0.5	\$ 3,000.00	\$ 1,500.00
Extra Piece of Equipment Including Fuel	Months	1	\$ 3,829.22	\$ 3,829.22
Miscellaneous Tools/Supplies	Lump Sum	1	\$ 414.00	\$ 414.00
Mulch for Mulch Jump	Cubic Yards	0	\$ 28.75	\$ -
Landscape and Irrigation Estimate	Estimate	1	\$ 6,500.00	\$ 6,500.00
Total Material Costs				\$ 33,048.38
FlowForm Features				
Rainbow Medium	Each	3	\$ 1,915.20	\$ 5,745.60
Shorebridge System	Each	1	\$ 19,266.24	\$ 19,266.24
Sunset Medium	Each	1	\$ 3,724.00	\$ 3,724.00
Total FlowForm Costs				\$ 28,735.84
Grand Total				\$ 82,952

City of Nanaimo
Bike Park Materials List - Skills Trail Only
October 28, 2016

Item		Specification	Unit	Quantity
Fill and Drainage				
Screened Surfacing Material (Screened On-Site)		NA	Cubic Yards	60
6" Drain Pipe in 3 meter Sections (Schedule 40)		Corix - 6" SDR28	Each	8
Dirt Fill For Features (Sourced On-Site)		NA	Cubic Yards	500
Ramp Decking - Cedar Boards S1S2E (1 smooth side, 2 edges)				
20" Board	Cedar	S1S2E	Boards	95
26" Board	Cedar	S1S2E	Boards	88
Screws and Trex for FlowForm Decking				
2.5" GRK Screw		NA	Each	222
12' Trex Composite Decking		NA	Each	16
Bolts for FlowForm Installation				
Stainless Steel	1/2" x 7" Expansion Anchor bolt with washer, nut	MC Master #92188A303	Each	56
Concrete Pre-Cast Footings				
Concrete	Full Size Flat Top	Lock Block	Each	4
Concrete	Half Height Flat Top	Lock Block	Each	20
Ramp Frames				
Rainbow Medium		FlowForm	Each	3.00
Sunset Medium		FlowForm	Each	1.00
Shorebridge System				
Cannon Large		FlowForm	Each	2.00
Cannon Small		FlowForm	Each	2.00
Half Sunset		FlowForm	Each	2.00
Turns		FlowForm	Each	2.00
Equipment				
Min Excavator Including Fuel		NA	Months	1
Skid Steer Including Fuel		NA	Months	1
Plate Compactor Including Fuel		NA	Months	1
Quad Rental Including Fuel		NA	Months	1
Screen Plant Including Fuel		NA	Months	0.25
4 CY Loader Including Fuel		NA	Week	0.50
Extra Piece of Equipment Including Fuel		NA	Months	1

ATTACHMENT D
Stevie Smith Community Bike Park at Beban Park
Confirmed In-Kind and Cash Contributions
Summary to October 31, 2016

In Kind Donations	171,452.20
Cash Donations	61,955.00
Sub-Total	233,407.20
Used to Fund Design	<u>11,000.00</u>
Balance Available for Construction	222,407.20

ATTACHMENT D

**Stevie Smith Community Bike Park at Beban Park
Confirmed In-Kind Contributions**

Service/Material	Quantity	Fair Market Value	Timeline
Rice Excavating			
Screen Plant	1 mth	\$ 3,000.00	
Mini Excavator & fuel	4 mths	\$ 24,148.18	
Skid Steer	4 mths	\$ 22,953.76	
Plate Compactor	4 mths	\$ 5,332.00	
Quad Rental w/fuel	4 mths	\$ 4,754.14	
Total Rice Excavating Donation		<u>\$ 60,188.08</u>	Fall 2016-Spring 2017
Four Star Waterworks Ltd			
Materials			
Drain Pipe			
Landscaping & Irrigation			
Total Four Star Waterworks		<u>\$ 50,306.36</u>	Until completed
Gogo Cedar Mill			
2x6 Cedar Special Lengths		\$ 1,734.88	one week
Total Gogo Cedar Mill		<u>\$ 1,734.88</u>	
Saw Mill Direct			
2x6 Cedar Special Lengths		\$ 1,734.88	two weeks
Total Saw Mill Direct		<u>\$ 1,734.88</u>	
Bedrock Redi-Mix Ltd			
Concrete Lock Blocks	30	\$ 2,400.00	
Total Bedrock Redi-Mix Ltd		<u>\$ 2,400.00</u>	Anytime
Robinson Rentals			
Plate Compactor Rental	4 mths	\$ 5,300.00	
Total Robinson Rentals		<u>\$ 5,300.00</u>	Anytime
Dolan Construction			
Mini Excavator w/operator	40 hours	\$ 3,018.00	
Total Dolan Construction		<u>\$ 3,018.00</u>	2016/2017 as required
Richard Nash Developments			
Skid Steer w/operator	40 hours	\$ 2,869.00	
Total Richard Nash Developments		<u>\$ 2,869.00</u>	2016/2017 as required
Lussier & Son Con Ltd			
3 hour Truck and Pup	3 hours	\$ 384.00	
Screened Topsoil	52 yards	\$ 1,300.00	
Total Lussier & Son Con Ltd		<u>\$ 1,684.00</u>	
M&J Tree Service			
Boom Truck/Chipper	1 Week	\$ 7,400.00	
Stump Grinder	48 Hours	\$ 6,000.00	
Boom Truck/Chipper	2.5 Days	\$ 3,885.00	
Total M&J Tree Service		<u>\$ 17,285.00</u>	2016/2017
IWC Excavation			
Excavator/Operator	32 hours	\$ 4,032.00	
IWC Excavation Tree Service		<u>\$ 4,032.00</u>	Work done in late 2015
Gyro Club of Nanaimo			
Ramps	5	\$ 16,000.00	
Picnic Tables		\$ 4,900.00	
Gyro Club of Nanaimo		<u>\$ 20,900.00</u>	
Total In kind Donations		<u><u>\$ 171,452.20</u></u>	